



CAMLOCK
SYSTEMS

PRODUCT SPECIFICATION

Series 500

SERIES 500

**HIGH-SECURITY
ELECTRONIC SWING HANDLE.**



OVERVIEW

High-security electronic system offers smart cabinet protection with versatile locking options.

Upgrade your cabinet security in the field with the Series 500. This impressive handle is built in stainless steel offering a robust, attack resistant solution to multi-point locking with interchangeable cylinders. Can be fitted with an optional gearbox and rod system for three-point locking (pictured).

Key features

- Specifically designed for street furniture, outdoor applications, utilities and critical infrastructure
- Keep your existing locks: S500 accept a variety of inserts, including cylinders and euro profiles
- Built-in anti-drill, anti-cut and anti-drive through protection
- Multi-point locking gearbox and rod system option

TECHNICAL DATA

| | |
|--------------------------|--|
| Protective features | Anti-drill, anti-cut and anti-punch through protection |
| Measurements | 200mm (L) x 45mm (W) x 11mm (D) |
| Material | Grade 316 stainless steel |
| Finish | Black e-coating |
| Fixings | Seven M6 fixings |
| Fixing hole measurements | Twin 50mm x 25mm cut out |
| Ingress protection | Gaskets fitted to: Handle, base, fixing boxes, and spindle o-rings |

**SMARTER
LOCKING**



CAMLOCK
SYSTEMS

PRODUCT SPECIFICATION

Series 500

TECHNICAL DRAWINGS

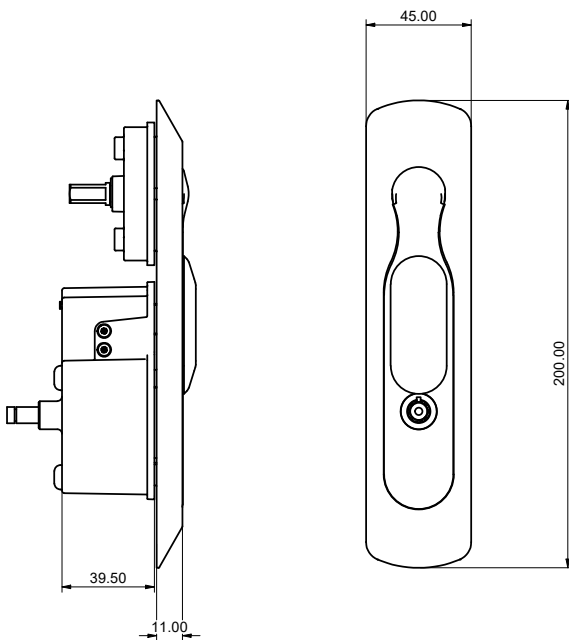

ADDITIONAL PRODUCT IMAGES

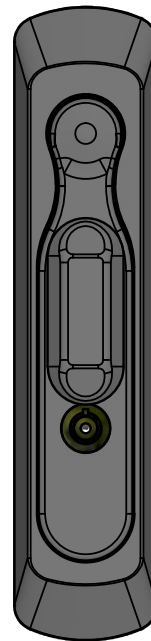

Seven M6 fixing bolts:
Three extra fixings have been added and strategically placed at the back of the handle to:

- Reinforce overall strength
- Provide more secure fit when affixed to cabinet
- Resists leverage attacks

Sleek, low profile handle.
Accepts the following inserts:

- Euro profile
- Cylinder inserts

